



Appendix A
Rectangular Waveguide

Waveguide Band	Designation	Dimensions (inch)	Frequency (GHz)	Cut-off (GHz)	Theoretical Attenuation Lowest to Highest Frequency (dB/ft)	Historic Designation	New MIL Part Number
Ku	RG-91/U	0.622 x 0.311	12.4-18.0	9.486	.064 - .030	UG-419/U	M3922/53-4/005
	WR-62					UG-541/U	M3922/59-2/001
K	RG-53/U	0.420 x 0.170	18.0-26.5	14.047	.17-.11	UG-595/U	M3922/54-4/001
	WR-42					UG-596A/U	M3922/59-2/003
A	RG-96/U	0.280 x 0.140	26.5-40.0	21.081	0.22-0.15	UG-425/U	M3922/67-2/004
						UG-599/U	M3922/54-4/003
	WR-28	UG-600/U	M3922/59-2/005				
B	RG-97/U	0.224 x 0.112	33.0-50.0	26.342	0.31-0.21	UG-381/U	M3922/67-2/005
						UG-383/U	M3922/53-4/005
	WR-22	MPI-719	M3922/59-2/001				
U	WR-19	0.188 x 0.094	40.0-60.0	31.357	0.39-0.27	MPI-719T	
						UG-383/U-M	M3922/53-4/005
						MPI-710	M3922/59-2/001
V	RG-98/U	0.148 x 0.074	50.0-75.0	39.863	0.57-0.39	MPI-720T	
	WR-15					UG-385/U	M3922/67-2/008
E	RG-99/U	0.122 x 0.061	60.0-90.0	48.350	0.78-0.53	UG-387/U	M3922/67-2/009
W	WR-10	0.100 x 0.050	75.0-110.0	59.010	1.02-0.71	UG-387/U-M	M3922/67-2/010
F	RG-138/U	0.080 x 0.040	90.0-140.0	73.764	1.52-0.98	MPI-714	M3922/74-001
	WR-8					UG-387/U-M	N/A
D	RG-136/U	0.065 x 0.0325	110.0-170.0	90.786	2.12-1.35	MPI-716	M3922/74-002
	WR-6					UG-387/U-M	N/A
G	RG-135/U	0.051 x 0.0255	140.0-220.0	115.71	3.05-1.93	MPI-715	M3922/74-003
	WR-5					UG-387/U-M	N/A

Modified (-M) means waveguide opening has been reduced appropriately. Screw and pin pattern are unchanged.

Appendix B Waveguide and Flange Dimensions (Round Flanges)

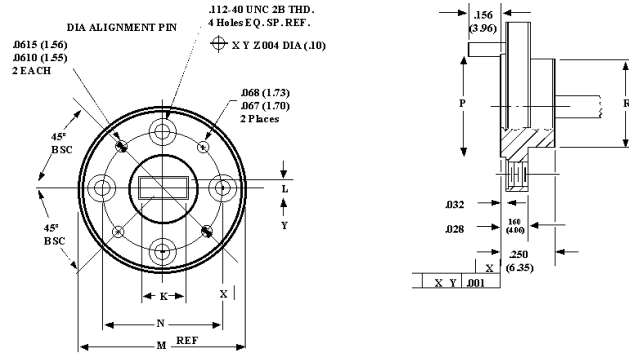

Waveguide Band	Frequency Band (GHz)	MIL Part Number M3922/67	EIA Waveguide Designation	Flange Designation	K ± .0015 (.04)	L ± .0015 (.04)	M ± .000/.002 (.05)	N BSC± .005	P ± .005 (.13)	R ± .005 (.13)
K	18.0 26.5	-004	WR-42	UC-425/U	.4200 (10.67)	.1700 (4.32)	1.125 (28.58)	.9375 (23.81)	.625 (15.88)	.625 (15.88)
Ka	26.5 40.0	-005	WR-28	UC-381/U	.2800 (7.11)	.1400 (3.56)	1.125 (28.58)	.9375 (23.81)	.500 (12.70)	.468 (11.89)
Q	33.0 50.0	-006	WR-22	UC-383/U	.2240 (5.69)	.1120 (2.84)	1.125 (28.58)	.9375 (23.81)	.500 (12.70)	.468 (11.89)
U	40.0 60.0	-007	WR-19	UC-383/U-M	.1880 (4.78)	.0940 (2.39)	1.125 (28.58)	.9375 (23.81)	.500 (12.70)	.468 (11.89)
V	50.0 75.0	-008	WR-15	UC-385/U	.1480 (3.76)	.0740 (1.88)	.750 (19.05)	.5625 (14.29)	.375 (9.53)	.312 (7.92)
E	60.0 90.0	-009	WR-12	UC-387/U	.1220 (3.10)	.0610 (1.55)	.750 (19.05)	.5625 (14.29)	.375 (9.53)	.312 (7.92)
W	75.0 110.0	-010	WR-10	UC-387/U-M	.1000 (2.54)	.0500 (1.27)	.750 (19.05)	.5625 (14.29)	.375 (9.53)	.312 (7.92)
F	90.0 140.0	N/A	WR-8	UC-387/U-M	.0800 (2.03)	.0400 (1.02)	.750 (19.05)	.5625 (14.29)	.375 (9.53)	.312 (7.92)
D	110.0 170.0	N/A	WR-6	UC-387/U-M	.0650 (1.65)	.0325 (.83)	.750 (19.05)	.5625 (14.29)	.375 (9.53)	.312 (7.92)
G	140.0 220.0	N/A	WR-5	UC-387/U-M	.0510 (1.30)	.0255 (.65)	.750 (19.05)	.5625 (14.29)	.375 (9.53)	.312 (7.92)

Appendix C Blank Round Flange Dimensions

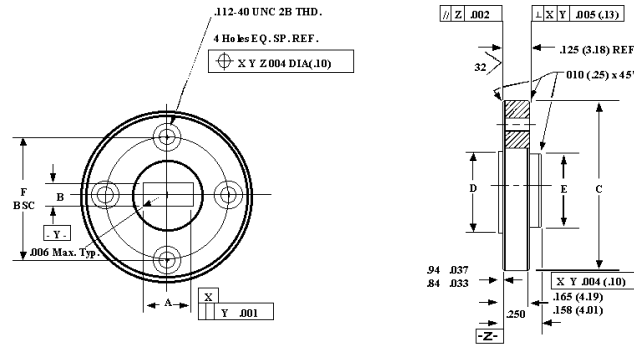

Band	Frequency Band (GHz)	MIL Part Number M3922/67	A ±.002/-0.000 (.05)	B ±.002/-0.000 (.05)	C ±.000/-0.002 (.05)	D ± .005 (.13)	E ± .005 (.13)	F BSC	Flange Designation
K	18.0 26.5	-004	.502 (12.75)	.252 (6.40)	1.125 (28.58)	.625 (15.88)	.625 (15.88)	.312 (7.92)	UC-425/U
Ka	26.5 40.0	-005	.362 (9.19)	.222 (5.64)	1.125 (28.58)	.500 (12.70)	.468 (11.89)	.9375 (23.81)	UC-381/U
Q	33.0 50.0	-006	.306 (7.77)	.194 (4.93)	1.125 (28.58)	.500 (12.70)	.468 (11.89)	.9375 (23.81)	UC-383/U
U	40.0 60.0	-007	.270 (6.86)	.167 (4.47)	1.125 (28.58)	.500 (12.70)	.468 (11.89)	.5625 (14.29)	UC-383/U-M
V	50.0 75.0	-008	.230 (5.84)	.156 (3.96)	.750 (19.05)	.375 (9.53)	.312 (7.92)	.5625 (14.29)	UC-385/U
E	60.0 90.0	-009	.204 (5.18)	.143 (3.63)	.750 (19.05)	.375 (9.53)	.312 (7.92)	.5625 (14.29)	UC-387/U
W	75.0 110.0	-010	.182 (4.62)	.132 (3.35)	.750 (19.05)	.375 (9.53)	.312 (7.92)	.5625 (14.29)	UC-387/U-M
F	90.0 140.0	N/A	.141 (3.58)	.101 (2.56)	.750 (19.05)	.375 (9.53)	.312 (7.92)	.5625 (14.29)	UC-387/U-M
D	110.0 170.0	N/A	.126 (3.20)	.094 (2.39)	.750 (19.05)	.375 (9.53)	.312 (7.92)	.5625 (14.29)	UC/387/U-M
C	140.0 220.0	N/A	.112 (2.84)	.089 (2.21)	.750 (19.05)	.375 (9.53)	.312 (7.92)	.9375 (23.81)	UC-387/U-M

Appendix D Waveguide and Flange Dimensions (pin-contact, threaded ring)

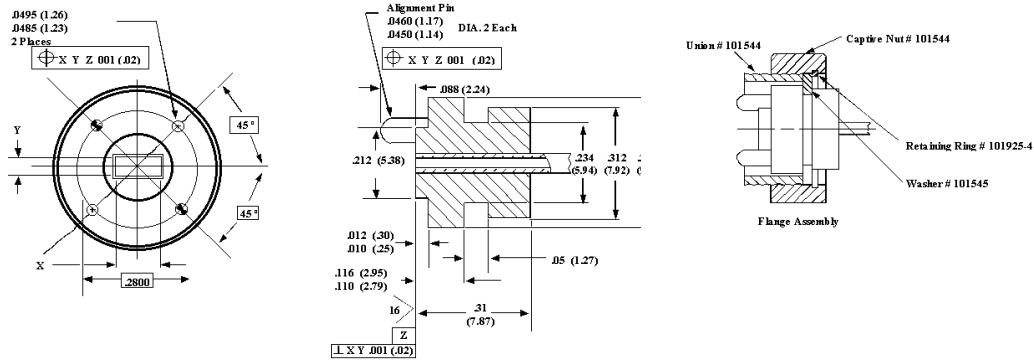

Band	Frequency Band (GHz)	MIL Part Number M3922/74	C inch (mm)	D inch (mm)	EIA Waveguide Designation
F	90.0-140.0	-001	.0800-(2.03)	.0400-(1.02)	WR8
D	110.0-170.0	-002	.0650-(1.63)	.0325-(.83)	WR7
G	140.0-220.0	-003	.0510-(1.30)	.0255-(.65)	WR5
H	180-260.50	-004	.430-(1.09)	.0215-(.55)	WR4
J	220.0-325.0	-005	.0340-(.86)	.0170-(.43)	WR3

Appendix E Blank Flange Dimensions (pin-contact, threaded ring)

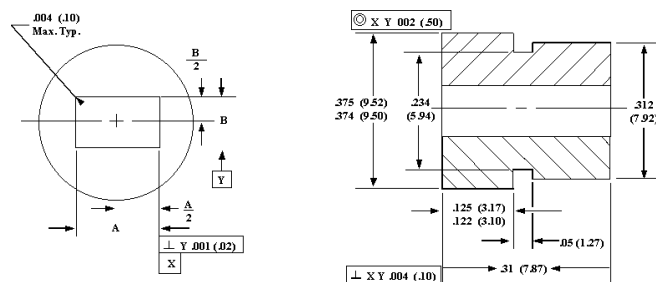

Band	Frequency Band (GHz)	A inch (mm)	B inch (mm)	EIA Waveguide Designation
F	90.0-140.0	.143-(3.63)	.103-(2.62)	WR8
D	110.0-170.0	.128-(3.25)	.098-(2.49)	WR7
G	140.0-220.0	.115-(2.92)	.089-(2.26)	WR5
H	170.0-260.5	.430-(1.09)	.0845-(2.15)	WR4
J	220.0-325.0	.106-(2.69)	.080-(2.03)	WR3

Appendix F WR-62 (Ku-band) Flange Blank and Waveguide Dimensions

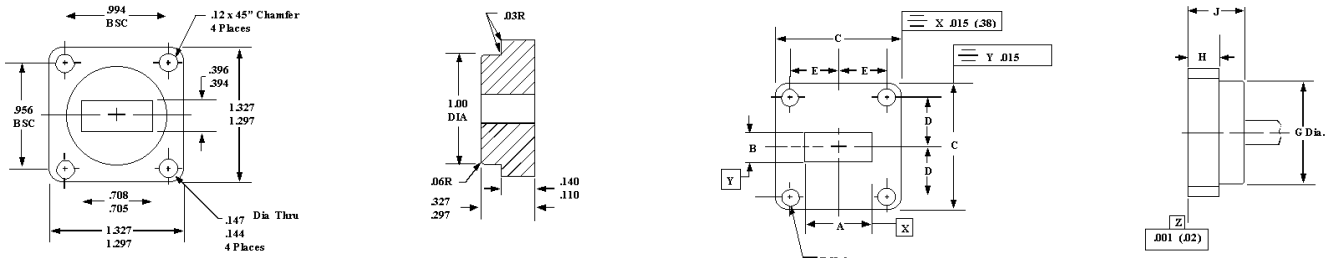

Flange Blank

Finished Waveguide & Flange

Band mm(mm)	Frequency Band (GHz) (.38)	MIL Part Number M3922/53	A inch	B inch (.08)	C .015 (.38)	D BSC (.38)	E BSC (.38)	F ±.003	G ±.015	H ±.015	J ±.015	Flange Bank
Ku	12.4- 18.0	-4/005	.622 ± .002 (15.8) (.05)	.311 ± .002 (.79) (.05)	1.312 (33.32)	4.78 (12.14)	.497 (12.62)	.144 (3.66)	1.000 (25.40)	.125 (3.18)	.313 (7.95)	UC-419/U

All dimensions in inch (mm)

Appendix G Waveguide and Flange Dimensions (Choke Flange)

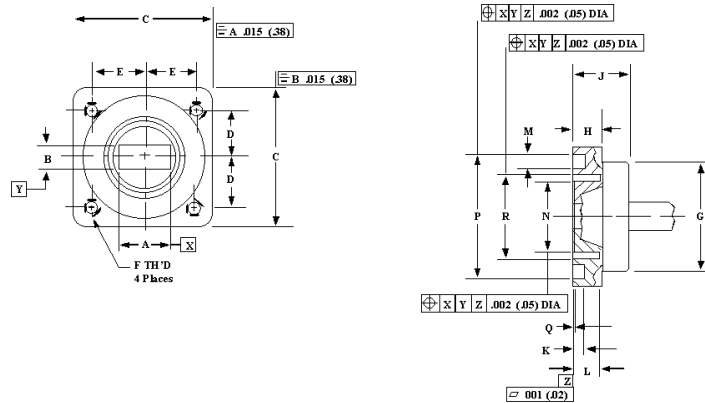

Band	Frequency Band (GHz)	MIL Part Number M3922/59	Flange Desig.	A	B	C .015 (.38)	D BSC	E BSC	F	G ±.015 (.38)	H ±.015 (.38)	J ±.015 (.38)	K ±.002 (.05)	L ±.002 (.05)	M ±.002 (.05)	N ±.002 (.05)	P ±.002 (.05)	Q ±.001 (.03)	R ±.002 (.05)
Ku	12.4 18.0	-2/001	UC541	.622±.002 (15.8)(.05)	.311±.002 (7.9)(0.05)	1.312 (33.32)	.478 (12.14)	.497 (12.62)	.138-32 UNC-2B	1.000 (25.40)	.188 (4.78)	.375 (9.53)	.113 (2.87)	.190 (4.83)	1.58 (4.01)	.710 (18.03)	1.208 (30.68)	.0075 (.19)	.828 (21.03)
K	18.0 26.5	-2/003	UC596	.420±.002 (10.67)(.05)	-.170±.002 (4.32)(.05)	.875 (22.23)	.335 (8.51)	.320 (8.13)	.112-40 UNC-2B	.625 (15.88)	.156 (3.96)	.285 (7.24)	0.42 (1.07)	.129 (3.28)	0.87 (2.21)	.472 (11.99)	.761 (19.33)	.005 (.13)	.536 (13.61)
Ka	26.5 40.0	-2/005	UC600	.280±.0014 (7.11)(.04)	.140±.0014 (3.56)(.04)	.750 (19.05)	.265 (6.73)	.250 (6.35)	.112-40 UNC-2B	.500 (12.70)	.109 (2.77)	.210 (5.33)	.050 (1.27)	.086 (2.18)	.096 (2.44)	.321 (8.15)	.596 (15.14)	.003 (.08)	.372 (9.45)

All dimensions in inch (mm)

Appendix H Square Flange and Waveguide Dimensions

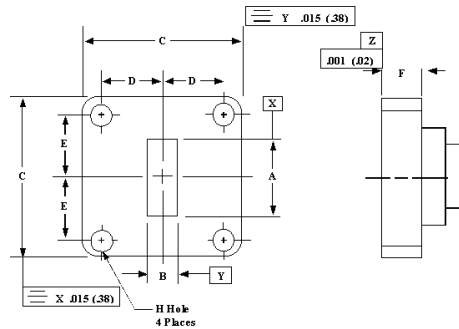

Band	Frequency Band (GHz)	MIL Part Number M3922/54-4	A ±.0015 (.04)	B ±.0015 (.04)	C	D BSC	E BSC	F	H	Flange
K	18.0 26.5	-001	.4200 (10.67)	.1700 (4.32)	.875±.015 (22.22)(.38)	.335 (8.51)	.320 (8.13)	.156±.015 (3.96)(.38)	.116±.002 (2.95)(.05)	UG-595/U
Ka	26.5 40.0	-003	.2800 (7.11)	.1400 (3.56)	.750±.005 (19.05)(1.3)	.265 (6.75)	.250 (6.35)	.109±.00 (2.77)(.38)	.116±.002 (2.95)(.05)	UG-599/U
Q	33.0 50.0	N/A	.2240 (5.69)	.1120 (2.84)	.750±.005 (19.05)(1.3)	.265 (6.75)	.250 (6.35)	.156±.005 (3.96)(.38)	.116±.002 (2.95)(.05)	(UG-599/UM)
Q	33.0 50.0	N/A	.2240 (5.69)	.1120 (2.84)	.750±.005 (19.05)(1.3)	.265 (6.75)	.250 (6.35)	.156±.005 (3.96)(.38)	.112-40 UNC-2B	
U	40.0 60.0	N/A	.1880 (4.78)	.0940 (2.39)	.750±.005 (19.05)(1.3)	.265 (6.75)	.250 (6.35)	.187±.005 (4.75)(.38)	.116±.002 (2.95)(.05)	
U	40.0 60.0	N/A	.1880 (4.78)	.0940 (2.39)	.750±.005 (19.05)(1.3)	.265 (6.75)	.250 (6.35)	.187±.005 (4.75)(.38)	.112-40 UNC-2B	

All dimensions in inch (mm)

Appendix I Flange Blanks

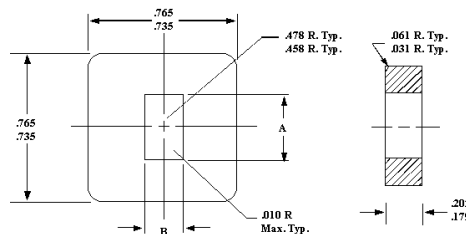

Flange Designation	A	B	C	D BSC	E BSC
UG 599A	.364 .362	.224 .222	.755 .745	.530	.500
UG 595K	.505 .503	.255 .253	.890 .860	.670	.640

Appendix J Circular Waveguide Sizes

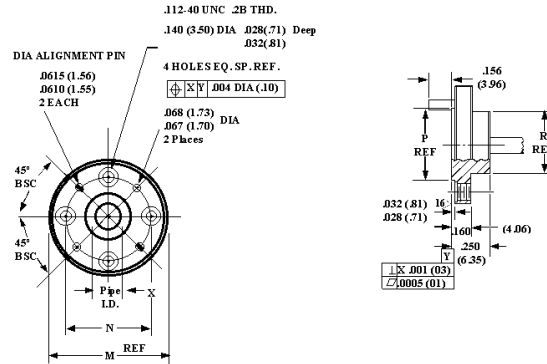

Band	Internal Diameter (inch)	Frequency Band
Ku-1	.660	12.4 - 14.6
Ku-2	.550	14.6 - 17.5
K-1	.470	17.5 - 20.5
K-2	.396	20.5 - 24.5
K-3	.328	24.5 - 26.5
A-0	.328	26 - 28.5
A-1	.281	28.5 - 33
A-2	.250	33 - 38.5
A-3	.219	38.5 - 43
B-0	.250	33 - 38.5
B-1	.219	38.5 - 43
B-2	.188	43 - 50
U-0	.219	38.5 - 43
U-1	.188	43 - 50
U-2	.165	50 - 58
V-0	.165	50 - 58
V-1	.141	58 - 68
V-2	.125	68 - 77
E-0	.141	58 - 68
E-1	.125	68 - 77
E-2	.110	77 - 87
E-3	.094	87 - 100
W-0	.110	77 - 87
W-1	.094	87 - 100
W-2	.082	100 - 112
F-0	.094	87 - 100
F-1	.082	100 - 112
F-2	.075	112 - 125
F-3	.067	125 - 140
D-0	.082	100 - 112
D-1	.075	112 - 125
D-2	.067	125 - 140
D-3	.059	140 - 160
G-0	.067	125 - 140
G-1	.059	140 - 220

Band	M +.000/.002 (.05)	N BSC	P +.005 (.13)	R +.005 (.13)	Flange Designation
Ku	1.44 (36.58)	1.250 (28.6)	.967 (24.6)	.967 (24.6)	
K	1.125 (28.58)	.9375 (23.8)	.625 (15.88)	.625 (15.88)	UG-425/U
Ka	1.125 (28.58)	.9375 (23.81)	.500 (12.70)	.468 (11.89)	UG-381/U
Q	1.125 (28.58)	.9375 (23.81)	.500 (12.70)	.468 (11.89)	UG-383/U
U	1.125 (28.58)	.9375 (23.81)	.500 (12.70)	.468 (11.89)	UG-385/U-M
V	.750 (19.05)	.5625 (14.29)	.375 (9.53)	.312 (7.92)	UG-387/U
E	.750 (19.50)	.5625 (14.29)	.375 (9.53)	.312 (7.92)	UG-387/U-M
W	.750 (19.50)	.5625 (14.29)	.375 (9.53)	.312 (7.92)	UG-387/U-M
F	.750 (19.50)	.5625 (14.29)	.375 (9.53)	.312 (7.92)	UG-387/U-M
D	.750 (19.50)	.5625 (14.29)	.375 (9.53)	.312 (7.92)	UG-387/U-M
G	.750 (19.50)	.5625 (14.29)	.375 (9.53)	.312 (7.92)	UG-387/U-M

All dimensions in inch (mm)



Appendix K
Circular Waveguide Sizes (Alternative Set)

Frequency Band	Frequency Range, GHz		Circular Waveguide Diameter, Inches(mm)
K	LOW	17-22	0.500(12.7)
	MID	21-27	0.396(10.1)
	HIGH	25-33	0.328(8.3)
Ka	LOW	25-33	0.328(8.3)
	HIGH	33-44	0.250(6.4)
Q	LOW	33-44	0.250(6.4)
	MID	38-50	0.219(5.6)
	HIGH	43-58	0.188(4.8)
U	LOW	38-50	0.219(5.6)
	MID	43-58	0.188(4.8)
	HIGH	58-77	0.141(3.6)
V	LOW	43-58	0.188(4.8)
	HIGH	58-77	0.141(3.6)
E	LOW	58-77	0.141(3.6)
	HIGH	75-100	0.109(2.8)
W	LOW	75-100	0.109(2.8)
	HIGH	88-116	0.094(2.4)
F	LOW	88-116	0.094(2.4)
	HIGH	110-146	0.075(1.9)
D	LOW	110-146	0.075(1.9)
	HIGH	140-185	0.059(1.5)
G	LOW	140-185	0.059(1.5)
	HIGH	183-240	0.046(1.2)



Appendix L

VSWR, Return Loss, Reflection Coefficient Conversion Table

Noise Figure to Noise Temperature Conversion Table

VSWR (xxx:1)	Return Loss (dB)	Reflection Coefficient
1.00	Infinity	0.000
1.01	46.06	0.005
1.02	40.09	0.010
1.03	36.61	0.015
1.04	34.15	0.020
1.05	32.26	0.024
1.06	30.71	0.029
1.07	29.42	0.034
1.08	28.30	0.038
1.09	27.32	0.043
1.10	26.44	0.048
1.20	20.83	0.091
1.30	17.69	0.130
1.40	15.56	0.167
1.50	13.98	0.200
1.60	12.74	0.231
1.70	11.73	0.259
1.80	10.88	0.286
1.90	10.16	0.310
2.00	9.54	0.333
2.50	7.36	0.429
3.00	6.02	0.500
3.50	5.11	0.556
4.00	4.44	0.600
4.50	3.93	0.636
5.00	3.52	0.667
6.00	2.92	0.714
8.00	2.18	0.778
10.00	1.74	0.818
100.00	0.17	0.980
Infinity	0.00	1.000

Noise Figure (dB)	Noise Temperature (K)
1.00	76
1.20	94
1.40	112
1.60	131
1.80	152
2.00	173
2.20	195
2.40	218
2.60	242
2.80	267
3.00	294
3.20	321
3.40	350
3.60	381
3.80	413
4.00	446
4.20	481
4.40	517
4.60	556
4.80	596
5.00	638
5.20	682
5.40	728
5.60	776
5.80	827
6.00	879
6.20	935
6.40	993
6.60	1053
6.80	1117
7.00	1184
7.20	1253
7.40	1326
7.60	1403
7.80	1483
8.00	1566
8.20	1654
8.40	1746
8.60	1842
8.80	1943
9.00	2048
9.20	2159
9.40	2274
9.60	2395
9.80	2522
10.00	2655



Appendix M

Conversion of uW, mW and W to dBm

Microwatt	
uW	dBm
1	-30.0
2	-27.0
3	-25.2
4	-24.0
5	-23.0
6	-22.2
7	-21.5
8	-21.0
9	-20.5
10	-20.0
20	-17.0
30	-15.2
40	-14.0
50	-13.0
60	-12.2
70	-11.5
80	-11.0
90	-10.5
100	-10.0
200	-7.0
300	-5.2
400	-4.0
500	-3.0
600	-2.2
700	-1.5
800	-1.0
900	-0.5
1000	0.0

Milliwatt	
mW	dBm
1	0.0
2	3.0
3	4.8
4	6.0
5	7.0
6	7.8
7	8.5
8	9.0
9	9.5
10	10.0
20	13.0
30	14.8
40	16.0
50	17.0
60	17.8
70	18.5
80	19.0
90	19.5
100	20.0
200	23.0
300	24.8
400	26.0
500	27.0
600	27.8
700	28.5
800	29.0
900	29.5
1000	30.0

Watt	
W	dBm
1	30.0
2	33.0
3	34.8
4	36.0
5	37.0
6	37.8
7	38.5
8	39.0
9	39.5
10	40.0
20	43.0
30	44.8
40	46.0
50	47.0
60	47.8
70	48.5
80	49.0
90	49.5
100	50.0
200	53.0
300	54.8
400	56.0
500	57.0
600	57.8
700	58.5
800	59.0
900	59.5
1000	60.0



Appendix N
Effect of VSWR on Transmitted Power and Return Loss

VSWR	VSWR, dB	Return Loss, dB	Transmission Loss, dB	Power Transmission, %	Power Reflection, %	VSWR	VSWR, dB	Return Loss, dB	Transmission Loss, dB	Power Transmission, %	Power Reflection, %
1	0.0		0.000	100.0	0.0	1.52	3.6	13.7	0.189	95.7	4.3
1.01	0.1	46.1	0.000	100.0	0.0	1.54	3.8	13.4	0.201	95.5	4.5
1.02	0.2	40.1	0.000	100.0	0.0	1.56	3.9	13.2	0.213	95.2	4.8
1.03	0.3	36.6	0.001	100.0	0.0	1.58	4.0	13.0	0.225	94.9	5.1
1.04	0.3	34.2	0.002	100.0	0.0	1.6	4.1	12.7	0.238	94.7	5.3
1.05	0.4	32.3	0.003	99.9	0.1	1.62	4.2	12.5	0.250	94.4	5.6
1.06	0.5	30.7	0.004	99.9	0.1	1.64	4.3	12.3	0.263	94.1	5.9
1.07	0.6	29.4	0.005	99.9	0.1	1.66	4.4	12.1	0.276	93.8	6.2
1.08	0.7	28.3	0.006	99.9	0.1	1.68	4.5	11.9	0.289	93.6	6.4
1.09	0.7	27.3	0.008	99.8	0.2	1.7	4.6	11.7	0.302	93.3	6.7
1.1	0.8	26.4	0.010	99.8	0.2	1.72	4.7	11.5	0.315	93.0	7.0
1.11	0.9	25.7	0.012	99.7	0.3	1.74	4.8	11.4	0.329	92.7	7.3
1.12	1.0	24.9	0.014	99.7	0.3	1.76	4.9	11.2	0.342	92.4	7.6
1.13	1.1	24.3	0.016	99.6	0.4	1.78	5.0	11.0	0.356	92.1	7.9
1.14	1.1	23.7	0.019	99.6	0.4	1.8	5.1	10.9	0.370	91.8	8.2
1.15	1.2	23.1	0.021	99.5	0.5	1.82	5.2	10.7	0.384	91.5	8.5
1.16	1.3	22.6	0.024	99.5	0.5	1.84	5.3	10.6	0.398	91.3	8.7
1.17	1.4	22.1	0.027	99.4	0.6	1.86	5.4	10.4	0.412	91.0	9.0
1.18	1.4	21.7	0.030	99.3	0.7	1.88	5.5	10.3	0.426	90.7	9.3
1.19	1.5	21.2	0.033	99.2	0.8	1.9	5.6	10.2	0.440	90.4	9.6
1.2	1.6	20.8	0.036	99.2	0.8	1.92	5.7	10.0	0.454	90.1	9.9
1.21	1.7	20.4	0.039	99.1	0.9	1.94	5.8	9.9	0.468	89.8	10.2
1.22	1.7	20.1	0.043	99.0	1.0	1.96	5.8	9.8	0.483	89.5	10.5
1.23	1.8	19.7	0.046	98.9	1.1	1.98	5.9	9.7	0.497	89.2	10.8
1.24	1.9	19.4	0.050	98.9	1.1	2	6.0	9.5	0.512	88.9	11.1
1.25	1.9	19.1	0.054	98.8	1.2	2.5	8.0	7.4	0.881	81.6	18.4
1.26	2.0	18.8	0.058	98.7	1.3	3	9.5	6.0	1.249	75.0	25.0
1.27	2.1	18.5	0.062	98.6	1.4	3.5	10.9	5.1	1.603	69.1	30.9
1.28	2.1	18.2	0.066	98.5	1.5	4	12.0	4.4	1.938	64.0	36.0
1.29	2.2	17.9	0.070	98.4	1.6	4.5	13.1	3.9	2.255	59.5	40.5
1.3	2.3	17.7	0.075	98.3	1.7	5	14.0	3.5	2.553	55.6	44.4
1.32	2.4	17.2	0.083	98.1	1.9	5.5	14.8	3.2	2.834	52.1	47.9
1.34	2.5	16.8	0.093	97.9	2.1	6	15.6	2.9	3.100	49.0	51.0
1.36	2.7	16.3	0.102	97.7	2.3	6.5	16.3	2.7	3.351	46.2	53.8
1.38	2.8	15.9	0.112	97.5	2.5	7	16.9	2.5	3.590	43.8	56.3
1.4	2.9	15.6	0.122	97.2	2.8	7.5	17.5	2.3	3.817	41.5	58.5
1.42	3.0	15.2	0.133	97.0	3.0	8	18.1	2.2	4.033	39.5	60.5
1.44	3.2	14.9	0.144	96.7	3.3	8.5	18.6	2.1	4.240	37.7	62.3
1.46	3.3	14.6	0.155	96.5	3.5	9	19.1	1.9	4.437	36.0	64.0
1.48	3.4	14.3	0.166	96.3	3.7	9.5	19.6	1.8	4.626	34.5	65.5
1.5	3.5	14.0	0.177	96.0	4.0	10	20.0	1.7	4.807	33.1	66.9